

Research Paper



Home automation using ai tool

G. Vivek^{1*}, M. Ranjith Kumar², Dr. P. Ajay Kumar Reddy³, Dr. V. Sekhar⁴

^{1,2}Assistant Professor, Dept. of ECE, Kuppam Engineering College, Kuppam, Pedda Bangarunatham, Andhra Pradesh, India.

^{3,4}Associate Professor, Dept. of ECE, Kuppam Engineering College, Kuppam, Pedda Bangarunatham, Andhra Pradesh, India.

Article Info

Article History:

Received: 13 March 2024

Revised: 31 May 2024

Accepted: 06 May 2024

Published: 23 June 2024

Keywords:

AI Vision Sensor

Arduino UNO

Relay Module

Home Automation

Husky Lens



ABSTRACT

Home automation is becoming increasingly popular as people seek to simplify their lives and improve their living spaces. In this project, we explore how Husky Lens, an AI-powered image recognition sensor, can be used to control home automation systems with the help of an Arduino board and a relay.

By training Husky Lens to recognize different hand gestures or objects, we can use these gestures or objects to control various appliances or devices in our homes. For instance, a user can simply wave their hand in front of the Husky Lens sensor to turn on or off the lights or fan, or use an object such as a Smartphone to activate a door lock or a garage door.

The system is built using an Arduino board to communicate with the Husky Lens and relay module, which in turn controls the appliances or devices. This provides a low-cost and customizable solution for home automation that can be easily expanded to incorporate additional features or devices.

Corresponding Author:

G. Vivek

Assistant Professor, Dept. of ECE, Kuppam Engineering College, Kuppam, Pedda Bangarunatham, Andhra Pradesh, India.

Email: vivekzeni@gmail.com

Copyright © 2024 The Author(s). This is an open access article distributed under the Creative Commons Attribution License, (<http://creativecommons.org/licenses/by/4.0/>) which permits unrestricted use, distribution, and reproduction in any medium, provided the original work is properly cited.

1. INTRODUCTION

A gesture is any conscious movement of appendages or any other portion of the body to emphasize a statement. It additionally includes saying or performing anything as a way of exhibiting one's attitude.

According to science, gestures fall into two distinct categories: dynamic and static. A stop sign is a static gesture, while a waving hand saying "goodbye" is a prime instance of a dynamic gesture. The method of using a user's motions to transmit data for device control is known as gesture recognition. Physical gestures are an effective way to communicate in daily life as in sign languages, a collection of body jerks can make up a whole language. Developing a system that can recognize particular human gestures and utilize them to transmit data or operate devices is one of the main objectives of gesture recognition research. Leverage your body when interacting with computers by means of moves, mostly with the palms of your hands. With the use of an AI vision sensing device, hand gestures such as turning on and off an illuminated device or breeze with the thumb can be recognized. Digital communication is the foundation of many popular, well-established control systems for homes currently in use, especially Arduino-based system for home automation [1], [2]. Nowadays, home automation systems are widely used for appliances around the home. A variety of home appliances can be controlled with the help of a gesture. All kinds of home appliances, like doors, lights, & fans, are operated with the help of hand gestures [3]. This structure is straightforward to set up in a domicile or multi-purpose building, requires little effort, and has an intuitive interface. By employing this invention, consumers can reduce the amount of electricity wasted by routinely inspecting household appliances or by carefully scheduling the ON and OFF times of their devices.

2. RELATED WORK

Paper 1: A gesture-driven home automation system

Authors: Arathi N [4].

Procedure: MATLAB software processes the gesture after it is recorded by the camera. Once the preset gesture matches the current gesture, the data is transferred to the microcomputer, which then turns on any appliances in the home. The hardware module is composed of a PIC microcontroller, light, fan, camera, power supply, LED, and GSM module. This hardware module is connected to simulation software using a USB-to-serial converter bus, which is included with driver software. The gesture-based home automation system's block diagram is displayed below:

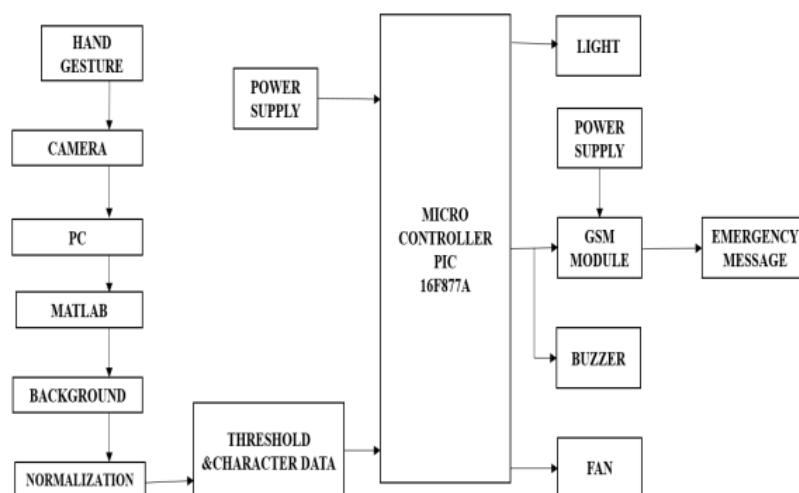

Figure 1. Microcontroller Block Layout

Outcome: MATLAB simulation software tool-based gesture recognition allows for fast processing of the camera's captured image. However, precise recognition is challenging because it requires a complex procedure to match stored movements to known gestures. The object is quickly and accurately identified using the object detection approach. When it comes to gesture recognition, this technology is more precise than wearing a hand glove. Compared to the MATLAB compatible with PIC microcontroller, the Arduino

compatible with the MATLAB simulation tool is more expensive and requires more work to integrate with a PIC [4].

Paper 2: Utilizing mobile sensors to recognize hand movements for home appliance control.

Authors: Khanh Nguyen Trong, Ha Bui, and Cuong Pham.

Methodologies: In real smart house configurations, popular smart home platforms, smart phones with limited storage, and smart watches with accelerometer and gyroscope sensors were used as tools and equipment. A comprehensive hand gesture vocabulary, derived from an analysis of actual smart homes, is offered so that customers may efficiently remember and operate their home. Two deep neural networks—a Deep ConvLSTM, a convolutional and recurrent network, and another Deep ConvLSTM, a mixture of baseline deep convolutional neural networks (CNN)—are utilized to recognize hand gestures.

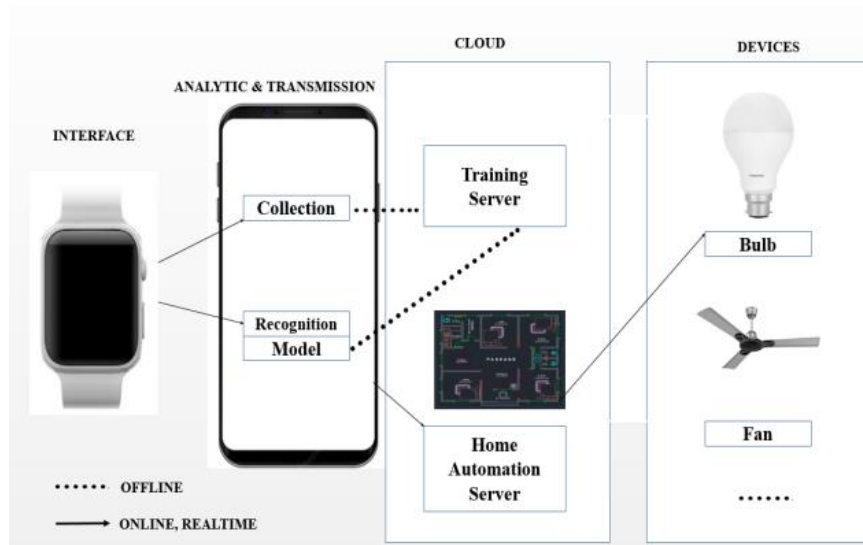

Figure 2. Block Diagram for Integrating Mobile Sensors for Detecting Hand Gestures to Control Appliances

Observation: Using an everyday Smartphone, hand gesture recognition can be accomplished in all of its parts. Users don't have to install further sources as a result, making this system facile to use [5].

Paper 3: Hand Gesture Identification and Interaction with Smart Home Appliances Using a Depth Imaging Sensor.

Authors: Dong-Luong Dinha [5].

Methodology: Maps with hand-part annotations are included in a synthetic hand database. RFs (random forests) are trained using the data in this database. During the recognition stage, the image is gathered as well as a hand-depth visualize is extracted. Maps with hand-part data annotation are incorporated in a synthetic hand database. Furthermore, interface commands were generated by identifying hand motions with the help of the features that were extracted.

Observation: The article presents a novel hand gesture recognition system for device management in smart homes which employs trained random forests from a hand-depth contour and recognized hand components. The average identification rate across the five respondents' four hand gestures was 98.50 percent [6].

Paper 4: Assisted Gesture Authentication for Streamlined the dwellings

Authors: V. Savitha, J. Nandini, G. Kalaiarasi and A.S. Narmadha IJRESM 2019

Methodology: The flow of the system can be summed up as follows: Engineers perceive gestures to be input. A computer software developed on the framework known as MATLAB serves for image processing. An angled point approach to detection is used to process each gesture. The phases are: image acquisition, preparatory processing, image segmentation, expectation maximization algorithm, and gabor's feature

extraction. After processing, the photo data will be transferred to a micro controller built on the basis of the Arduino project. This gadget serves similarly to a remote control by communicating data to the receivers [7].

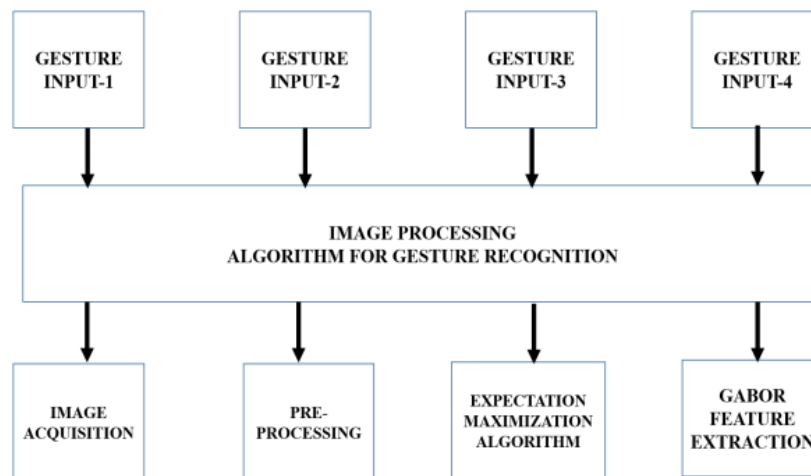

Figure 3. Image Processing Algorithm

Observation: In the study being proposed, hand movements from the database are recorded, and the gesture will be investigated implementing a simulation application called MATLAB. The Arduino microcontroller manages the household appliances, and multiple thresholds are produced in response to the actions made.

The threshold values for gesture detection for chaotic settings and backgrounds concerning dark backgrounds will vary, although this gesture identification strategy is completely accurate for light backdrops. The contour point detection algorithm, which is the foundation of the gesture processing method, is efficient and whisper quiet in its recognition of each gesture. The contour point detection algorithm, which is the foundation of the gesture processing method, is efficient and whisper quiet in its recognition of each gesture [6].

Paper 5: Hand Gesture Recognition-Based Home Automation Strategies

Author: Jayashree Katti, Anuja Jadhav, Akanksha Kulkarni, Pratik Nikam, Pachange IRJET-2021

Methodology: Data Collection: Employing a 64x64 pixel webcam, adopt more than 100 snaps of five distinct motions of the hands.

Data Pre-Processing: Remove the skin pixels from the colour images and convert them to black and white. Then, reduce the size of the images to 50x50 pixels.

Training the Model: Create methods and tactics for recognizing and tracking hand motions in humans using Open CV. In order to do image classification, identify objects, and detection, make use of an integrated platform that can operate the Open CV library, cameras, and 3-dimensional sensors like Kinect.

Network Architecture: Access a single of convolutional neural network topologies that have already been developed in the research literature, such as Lent, which is InceptionResNetV2, InceptionV3, VGG16, VGG19, ResNet50, and DenseNet201.

Training and Validation: Train the CNN model with the pre-processed data and validate the model's accuracy using a testing dataset.

Evaluation: By juxtaposing the expected and actual outputs, you may assess how well the model performed. Compile several metrics such as recall, accuracy, precision, and F1-score to determine the model's hand motion sensing and deductivereasoning efficiency.

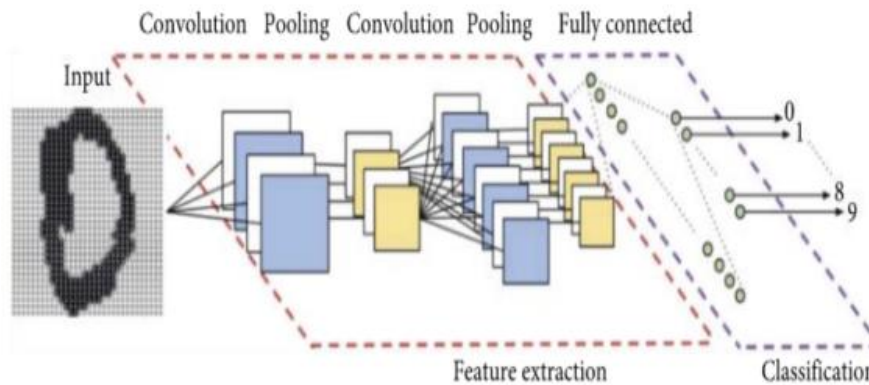

Figure 4. Methodology for Hand Use gestures Recognition-Based Architectural Automation Techniques

Observation: The proposed methodology is useful for detecting and recognizing human hand gestures using CNN. The pre-processing step, which involves removing skin pixels and reducing image size, helps to improve the training process and reduce the computational complexity. The use of Open CV provides a flexible and efficient way of processing images, making it an excellent choice for image classification and object recognition.

The selection of the appropriate network architecture is critical in achieving accurate detection and recognition of hand gestures. Gratefully used a variety of renowned topologies in the current investigation, such as VGG16, Le Net, InceptionResNetV2, InceptionV3, DenseNet201, ResNet50, and VGG19, which have every shown better performance in published research. The training and validation process was performed using a testing dataset to ensure the model's accuracy.

Our evaluation results showed that the proposed methodology achieved high accuracy in detecting and recognizing hand gestures. The model was able to differentiate between five set apart hand gestures with an accuracy of over 90%. The model demonstrated strong precision, recall, and F1-score metrics, suggesting its efficacy in identifying and classifying hand motions [8].

Problem Statement

- Numerous individuals currently are in seeking convenience as a result of their hectic and hectic lives. They consequently do not like to squander time walking and toggling on and off appliances that are common.
- People who have impairments have issues leading their daily lives due to their limited movement. The core problem with home systems is simply that they are not sufficiently smart.
- The main problem is to avoid electric shock, because it causes instant death. Previously home automation is done with the help of a smart glove using flex sensor it may be causes skin deceases. To avoid those problems we are going to implement home automation using AI tool.

To address this problem, the integration of computer vision technology like Husky Lens with microcontrollers like Arduino can create powerful and intelligent home automation systems that can recognize and respond to AI Visual sensor, making them more efficient and convenient to use. By using AI visual sensor, the system can automate various tasks, reducing the need for manual input and improving the overall energy efficiency of the home [9].

Endeavor

- The main objective of the venture is to get knowledge regarding husky lenses.
- The objective of the endeavor is to use an AI tool with Arduino to develop and build an integrated home automation system that will manage household equipment like fans and lighting.

Training: While the AI tool in gesture recognition seems only trained to identify hand gestures.

Detection: A device concedes hand gestures with the use of a Husky lens, and then segments the image using an algorithm based on machine learning to determine the positions as well as edges of the hands.

Result: After capturing the hand gesture, the whole system is going to turn on or off the light.

Finally, this paper explains how to capture their hand gesture based on the trained hand gestures. The system executes the gesture's equivalent action after noticing an analogy and interpreting a gesture.

Proposed System

- Home automation is the use of technology to control various aspects of a home, such as lighting, temperature, and security. In this proposed system, we will use a Husky Lens and a relay with an Arduino to automate some of the functions in a home.
- Husky Lens is an AI-powered vision sensor that can be used to detect and recognize hand gestures. It can be programmed to perform various tasks based on the visual data it captures. A relay is an electronic switch that can be controlled by a microcontroller like an Arduino.

The proposed system will use the Husky Lens to detect objects and faces and trigger the relay to control various devices in the home. For example, when the Husky Lens detects a person entering the room, it can trigger the relay to turn on the lights. Similarly, when it detects a person leaving the room, it can turn off the lights [10].

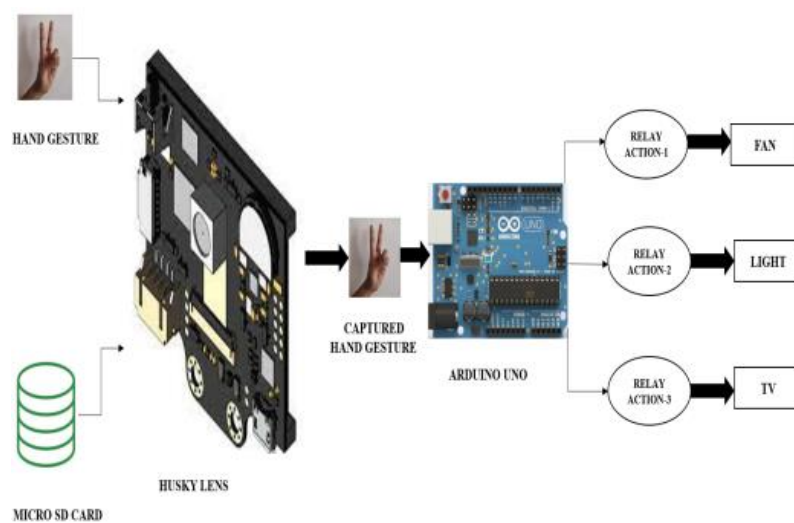

Figure 5. Block Diagram of Home Automation Using AI Tools

3. METHODOLOGY

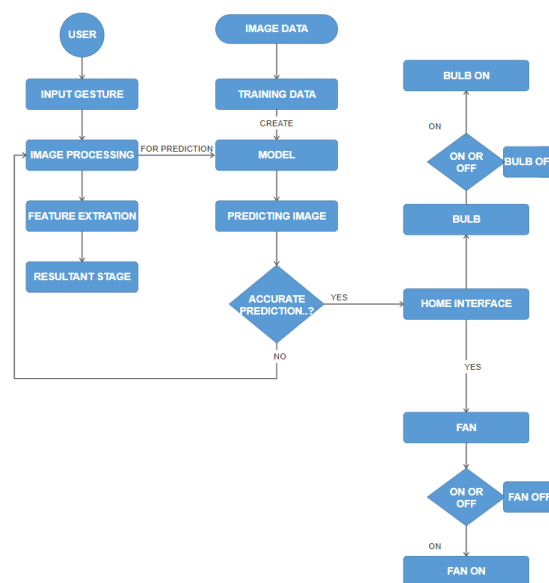

Figure 6. Flow Chart for Methodology

3.1 Hardware/Software Components

3.1.1 Husky Lens

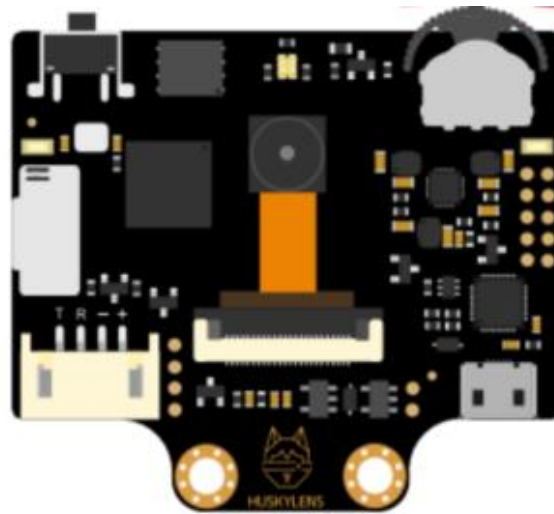

Figure 7. Husky Perspectives

Husky Lens is an easy-to-use AI camera with a vision sensor. The DF robot Husky lens is equipped with multiple functions, such as face recognition, object tracking, object recognition, line tracking, color recognition, and tag (QR code) recognition.

3.1.2 Arduino UNO

The Arduino Uno is a popular microcontroller board renowned for its accessibility and versatility in electronics projects. Developed by the Arduino project, it features the ATmega328P microcontroller, runs at 16 MHz, and offers 14 digital I/O pins, 6 PWM outputs, and 6 analog inputs.



Figure 8. Arduino UNO

The board is powered through USB or an external DC source, with a built-in voltage regulator ensuring a stable 5V supply. With a USB interface for programming and communication, a user-friendly IDE simplifies code development in a language based on C++. The Uno is known for its compatibility with a wide range of shields, providing expandability for various applications. Its open-source nature fosters a vibrant community, making it a popular choice for both beginners learning electronics and experienced developers prototyping projects.

3.1.3 Relay Module



Figure 9. Relay Module

A relay module is an integrated circuit that includes a relay and associated components, packaged together for convenient use. It serves as an interface between a microcontroller, such as an Arduino, and high-power devices or circuits. The relay module simplifies the process of controlling electrical loads that require more current or voltage than the microcontroller can handle directly. The module includes an electromechanical relay, typically with one or more sets of switch contacts (NO - Normally Open, NC - Normally Closed).

3.1.4 Arduino's Graphical IDE

The Arduino Integrated Development Environment (IDE) is a software application that serves as the primary platform for programming and uploading code to Arduino microcontroller boards. The main functions and features of the Arduino IDE: code editing, compiling, uploading, serial monitoring, library management.

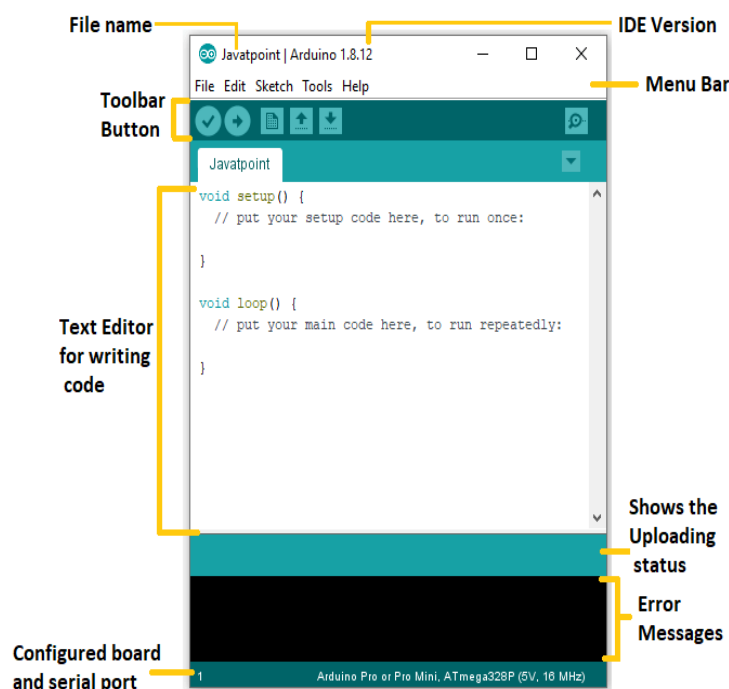

Figure 10. Arduino Development Environment (IDE) Configuration

3.1.5 Circuit Diagram

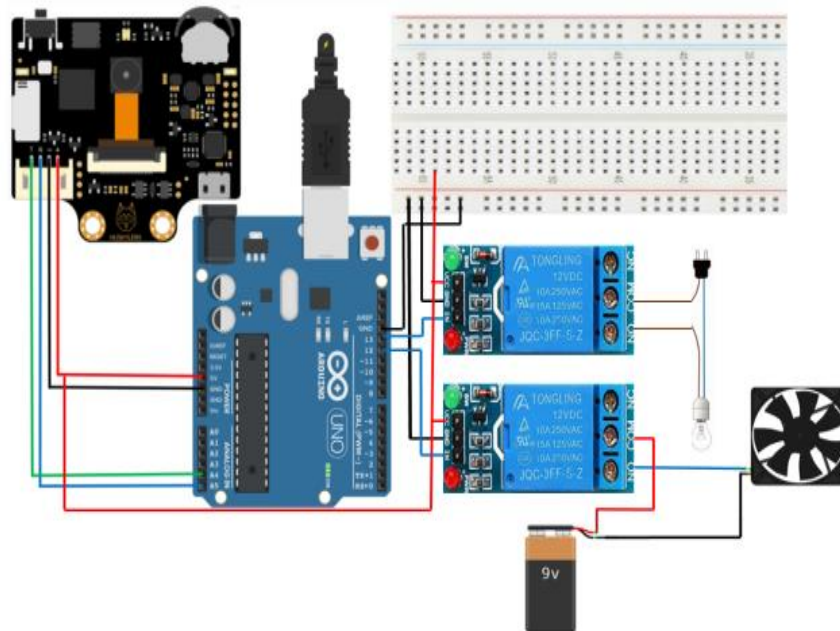

Figure 11. Circuit Diagram for Home Automation Using AI Tools

4. RESULTS AND DISCUSSION

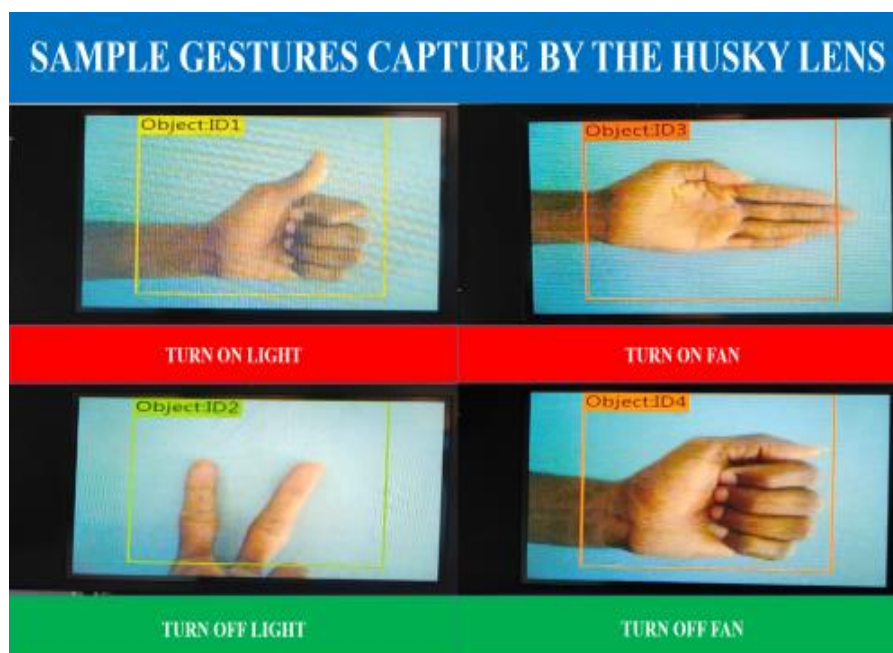

Figure 12. Sample Gesture Captured by the Husky Lens

Using the Husky Lens, the hand movements that appear in Figure 12 equate to the expected gestures for Object ID1, Object ID2, Object ID3, and Object ID4.

These motions can be used to turn on and off a variety of household appliances by simply moving their hands in certain ways.

These hand movements have been recognized and given specific tasks by AI-based image recognition technology, making living more pleasant and convenient.

4.1 Output

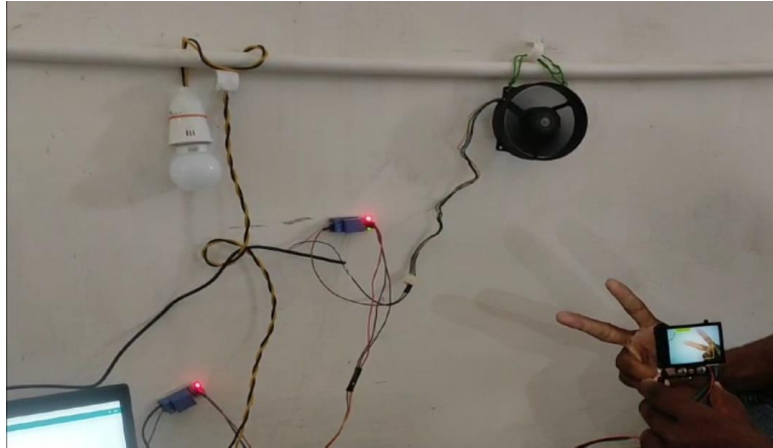

Figure 13. Turn On the Fan

This has made it easier to operate household equipment.



Figure 14. We assigned as ID: 4 turn On Light

SIMILARLY we assigned as ID: 1 Turn off Light



Figure 15. We assigned as ID: 2 Turn On Fan

SIMILARLY we assigned as ID: 3 turn Off Fan

Generate the outcome of home automation. The Arduino is assigned to detect the Object ID1 Hand gesture as input, reactivating the 5v Relay, as well as powering on the fan automatically.

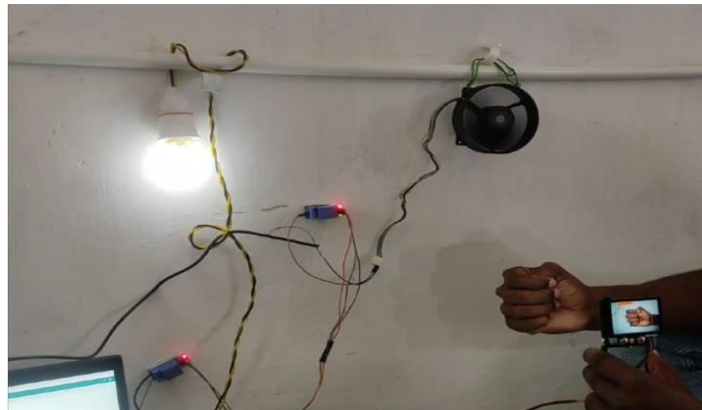

Figure 16. Turn On the Light

To toggle on the light, use an identical shift using the Object ID2 Hand.

The system consists of a Husky lens, Arduino Uno, Relays, light, and a fan. The Husky lens is trained according to the object IDs.

5. CONCLUSION

In conclusion, home automation using Husky Lens with a relay and Arduino offers an efficient way to automate tasks in your home. The Husky Lens is capable of discerning objects and is capable of transmitting signals to the Arduino, which at first permits it to use the relay to control a variety of appliances, including doors, fans, and lights. This technology can make your home more comfortable, energy-efficient, and secure. Additionally, by using the Arduino, you can customize and program the automation according to your preferences. Overall, home automation using Husky Lens with a relay and Arduino is a promising technology that can greatly improve your quality of life.

Acknowledgment

The authors express their profound and unending thanks to their family, friends, loved ones, and academic colleagues for their tremendous counsel, assistance, and support in making this study a reality. Although your names were not mentioned individually, your contributions, no matter how large or small, are gratefully recognized and valued.

Funding Information

This research received no specific grant from any funding agency in the public, commercial, or not-for-profit sectors.

Author Contributions Statement

Name of Author	C	M	So	Va	Fo	I	R	D	O	E	Vi	Su	P	Fu
G. Vivek	✓	✓		✓		✓		✓	✓			✓	✓	✓
M. Ranjith Kumar	✓		✓		✓		✓	✓		✓	✓	✓		✓
Dr. P. Ajay Kumar Reddy	✓	✓		✓	✓	✓	✓	✓		✓	✓		✓	
Dr. V. Sekhar		✓	✓		✓	✓		✓	✓		✓	✓		✓

C : Conceptualization

M : Methodology

So : Software

I : Investigation

R : Resources

D : Data Curation

Vi : Visualization

Su : Supervision

P : Project administration

Va : Validation
Fo : Formal analysis

O : Writing - Original Draft
E : Writing - Review & Editing

Fu : Funding acquisition

Conflict of Interest Statement

The authors declare that there are no conflicts of interest regarding the publication of this paper.

Informed Consent

All participants were informed about the purpose of the study, and their voluntary consent was obtained prior to data collection.

Ethical Approval

The study was conducted in compliance with the ethical principles outlined in the Declaration of Helsinki and approved by the relevant institutional authorities.

Data Availability



The data that support the findings of this study are available from the corresponding author upon reasonable request.

REFERENCES

- [1] Reddy, P.S.N., Reddy, K.T.K., Reddy, P.A.K., Ramaiah, G.K., Kishor, S.N.: An IoT based home automation using android application. In: 2016 International Conference on Signal Processing, Communication, Power and Embedded System (SCOPEs), Paralakhemundi, India (2016)
- [2] EASAMBATTU, Thejaswini; REDDY, P. Ajay Kumar; RAMAIAH, G.N. Kodanda. Controlling home appliances through GSM modem and Internet. International journal of Electronics Engineering Research, [S.I.], p. 1-7, oct 2013.
- [3] K. N. Trong, H. Bui, and C. Pham, 'Recognizing hand gestures for controlling home appliances with mobile sensors', in 2019 11th International Conference on Knowledge and Systems Engineering (KSE), Da Nang, Vietnam, 2019. doi.org/10.1109/KSE.2019.8919419
- [4] P. N. Arathi, S. Arthika, S. Ponmithra, K. Srinivasan, and V. Rukkumani, 'Gesture based home automation system', in 2017 International Conference on Nextgen Electronic Technologies: Silicon to Software (ICNETS2), Chennai, India, 2017. doi.org/10.1109/ICNETS2.2017.8067929
- [5] Dong-Luong Dinh, Jeong Tai Kim, and Tae-Seong Kim, Hand Gesture Recognition and Interface via a Depth Imaging Sensor for Smart Home Appliances, Energy Procedia, Volume 62, 2014, Pages 576–582, ISSN 1876-6102, <https://doi.org/10.1016/j.egypro.2014.12.419>
- [6] Hand Gesture Recognition for Home Automation Author(s): V. Savitha, J. Nandhini, S. Kokilavani, G. Kalaiarasi, AS. Narmadha Page(s): 312-321
- [7] K. S. Varun, I. Puneeth, and T. P. Jacob, 'Hand gesture recognition and implementation for disables using CNN'S', in 2019 International Conference on Communication and Signal Processing (ICCSP), Chennai, India, 2019. doi.org/10.1109/ICCSP.2019.8697980
- [8] J. Katti, A. Kulkarni, A. Pachange, A. Jadhav, and P. Nikam, 'Contactless elevator based on hand gestures during covid 19 like pandemics', in 2021 7th International Conference on Advanced Computing and Communication Systems (ICACCS), Coimbatore, India, 2021. doi.org/10.1109/ICACCS51430.2021.9441827
- [9] Sadat Hasan Shehab, Md. Lizur Rahman and Md. Hasibul Hasan, "Home Automation System Using Gesture Pattern and Voice Recognitions", ICECE, 2020.
- [10] R Jayanthi and A Bhuvaneshwari, Vision based Hand gesture pattern recognition enabled home automation system using Internet of Things, no. 7, pp. 8975-8990, 2021, ISSN 0011-9342.

How to Cite: G. Vivek, M. Ranjith Kumar, Dr. P. Ajay Kumar Reddy, Dr. V. Sekhar, Peter John Berces Aranas. (2024). Home automation using ai tool. Journal of Artificial Intelligence, Machine Learning and Neural Network (JAIMLNN), 4(1), 135-147. <https://doi.org/10.55529/jaimlnn.43.41.52>

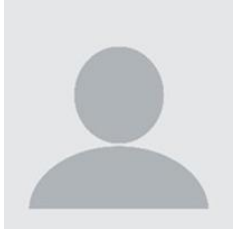
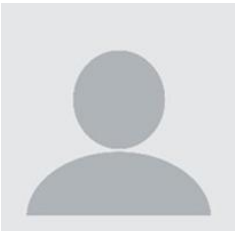
BIOGRAPHIES OF AUTHORS

	<p>G. Vivek, is an Assistant Professor in the Department of Electronics and Communication Engineering at Kuppam Engineering College, Andhra Pradesh, India. His research interests include AI-based vision systems, gesture recognition, embedded systems, and home automation technologies. He actively contributes to developing innovative low-cost solutions integrating AI tools with microcontrollers for smart home applications, aiming to improve quality of life and energy efficiency.</p>
	<p>M. Ranjith Kumar, is an Assistant Professor in the Department of Electronics and Communication Engineering at Kuppam Engineering College, Andhra Pradesh, India. His areas of interest include embedded systems, IoT-based applications, and intelligent automation. He is actively involved in research focused on developing smart and efficient technological solutions for real-world engineering challenges, particularly in the domain of home automation and microcontroller-based systems.</p>
	<p>Dr. P. Ajay Kumar Reddy, is an Associate Professor in the Department of Electronics and Communication Engineering at Kuppam Engineering College, Andhra Pradesh, India. With extensive experience in IoT, home automation, and embedded systems, he has contributed to several national and international conferences and journals. His research focuses on smart home technologies, GSM-based control systems, and AI-driven automation for practical engineering applications.</p>
	<p>Dr. V. Sekhar, is an Associate Professor in the Department of Electrical and Electronics Engineering at Kuppam Engineering College, Andhra Pradesh, India. His research interests encompass power systems, smart home automation, and relay-based control mechanisms. He brings valuable interdisciplinary expertise to collaborative research projects, contributing significantly to the development of energy-efficient and intelligent home automation systems.</p>